

E19-TOP

HYDRAULIC DIAGRAM

PHASE TO PHASE

E19-TOP – Hydraulic Diagram – Phase to Phase

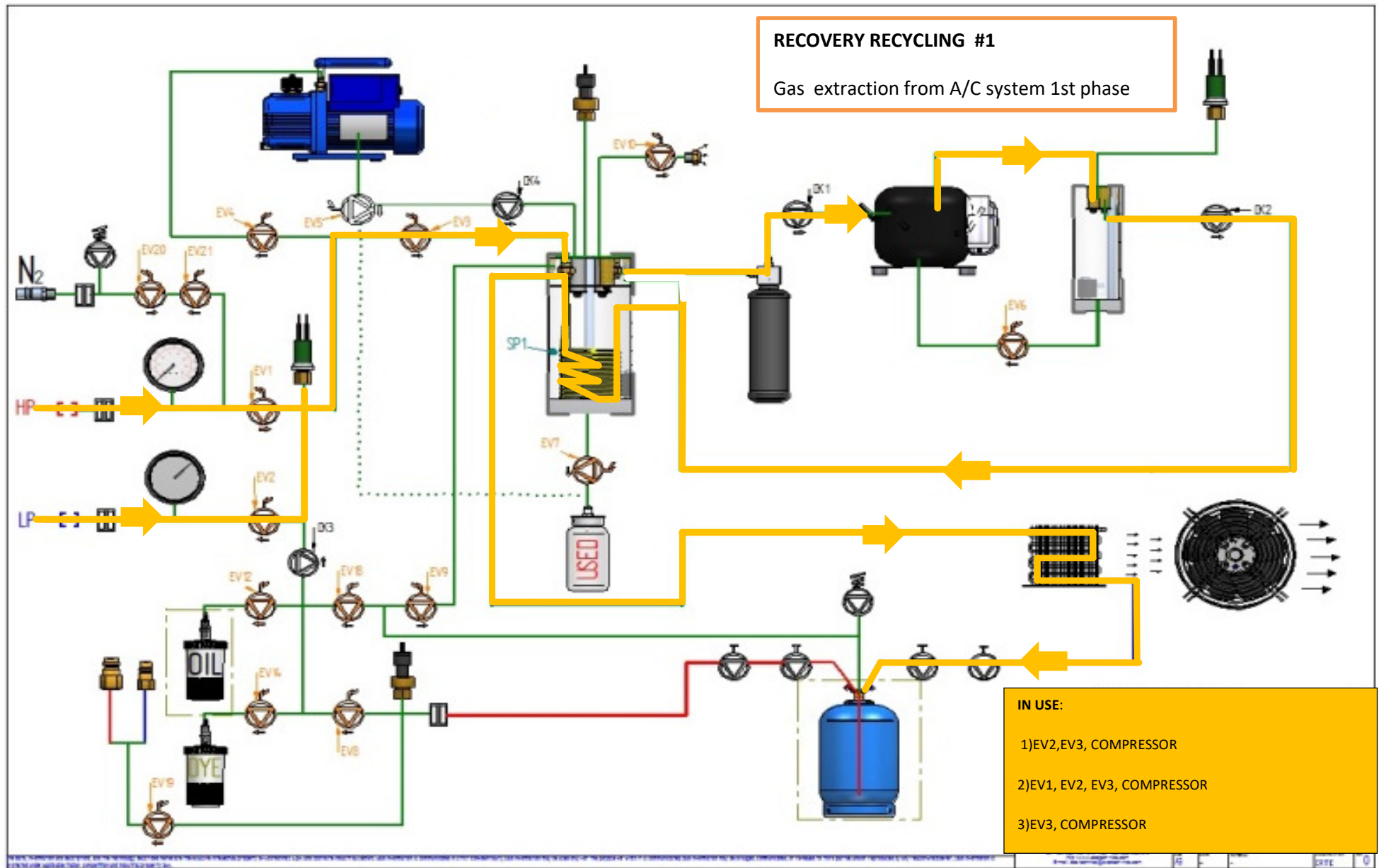

E19-TOP – Hydraulic Diagram – Phase to Phase

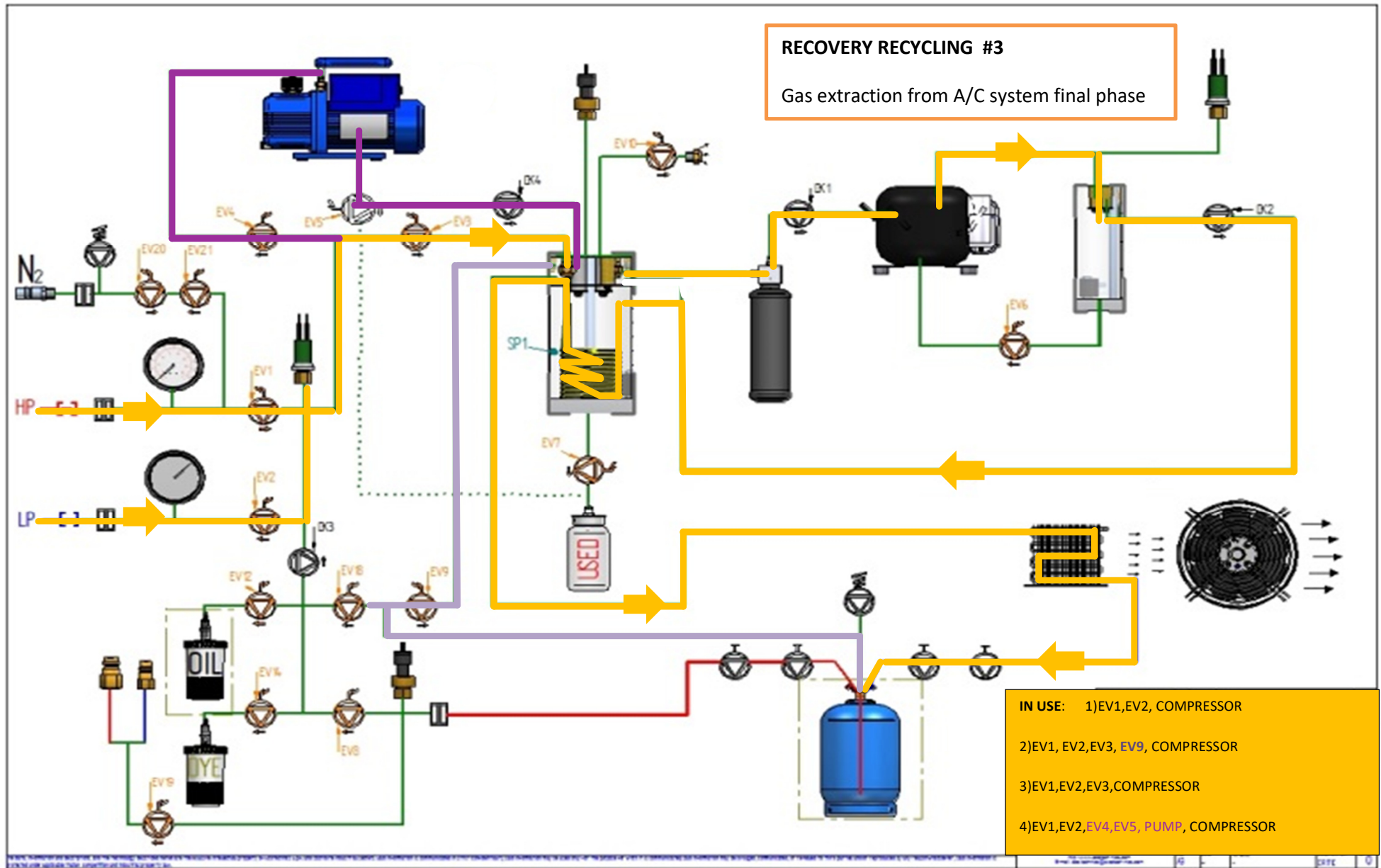

E19-TOP – Hydraulic Diagram – Phase to Phase

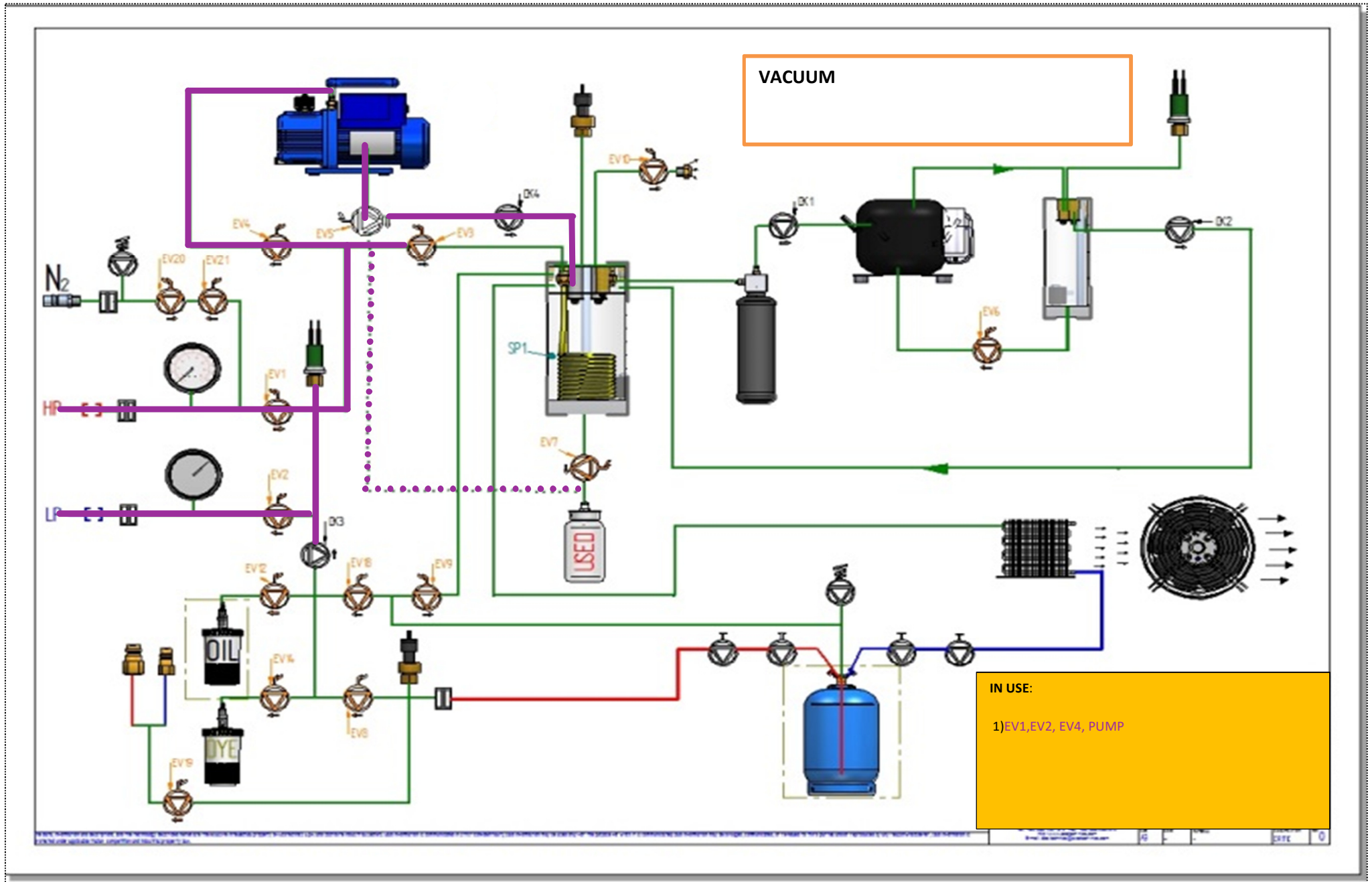

E19-TOP – Hydraulic Diagram – Phase to Phase

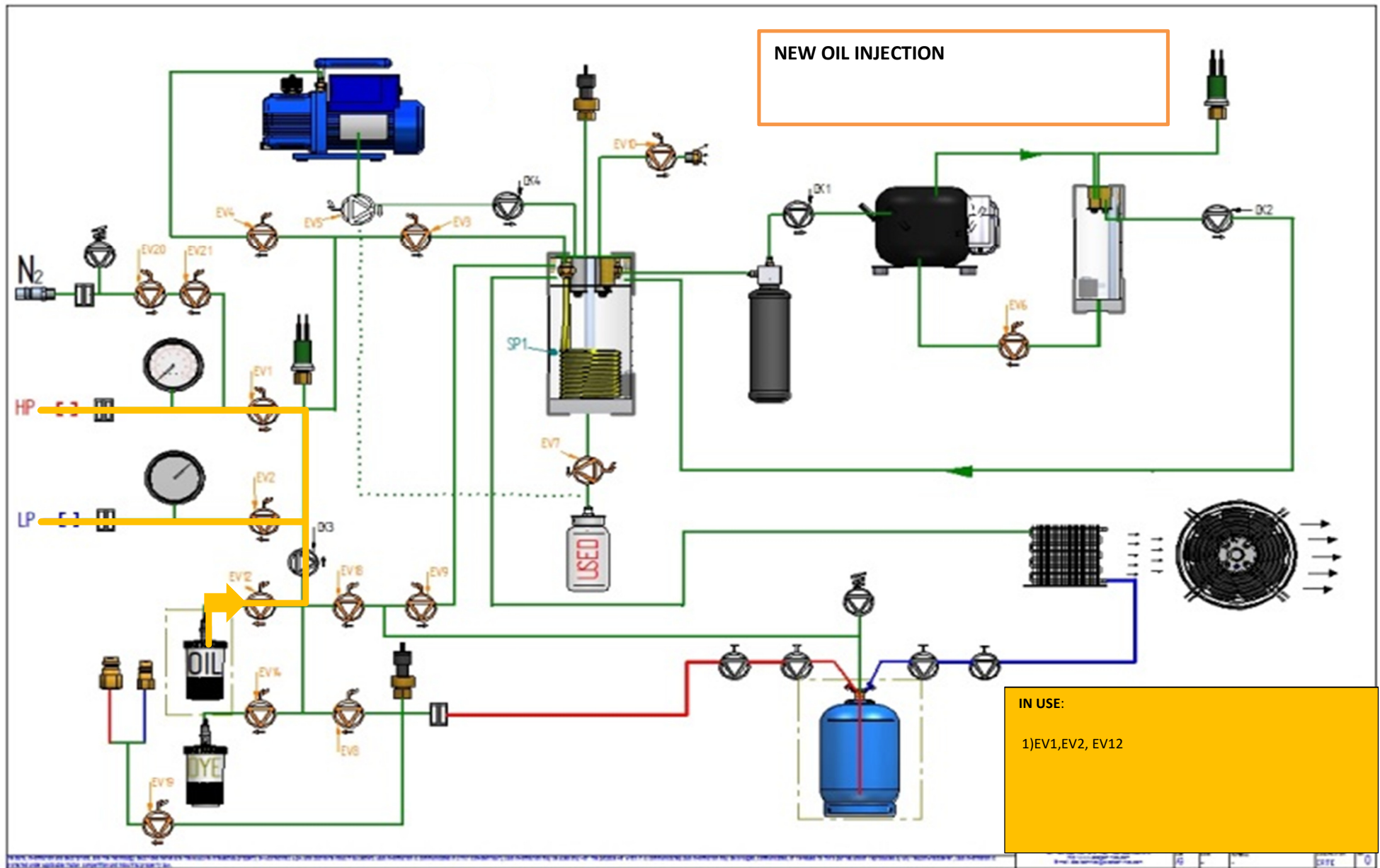

E19-TOP – Hydraulic Diagram – Phase to Phase

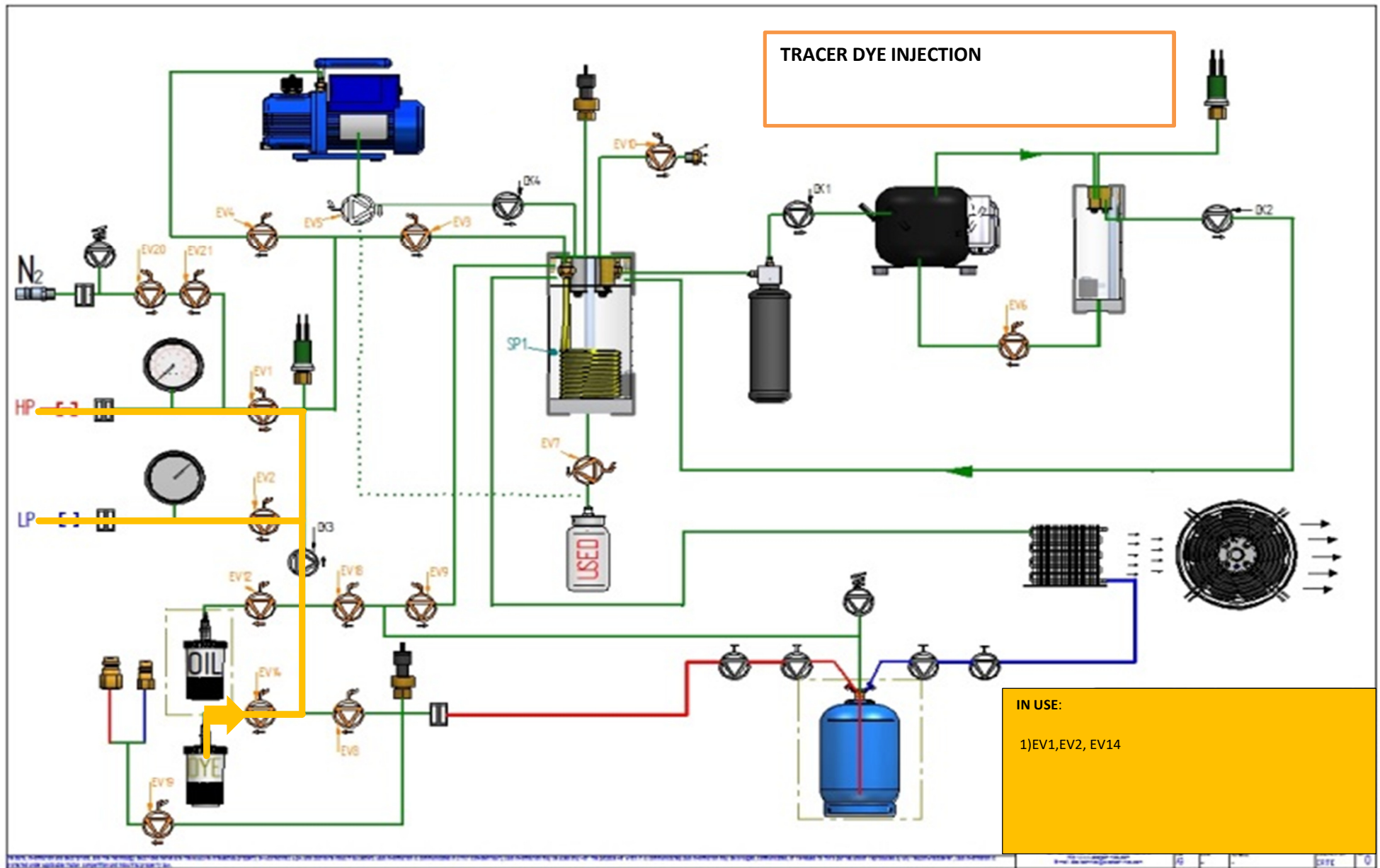

E19-TOP – Hydraulic Diagram – Phase to Phase

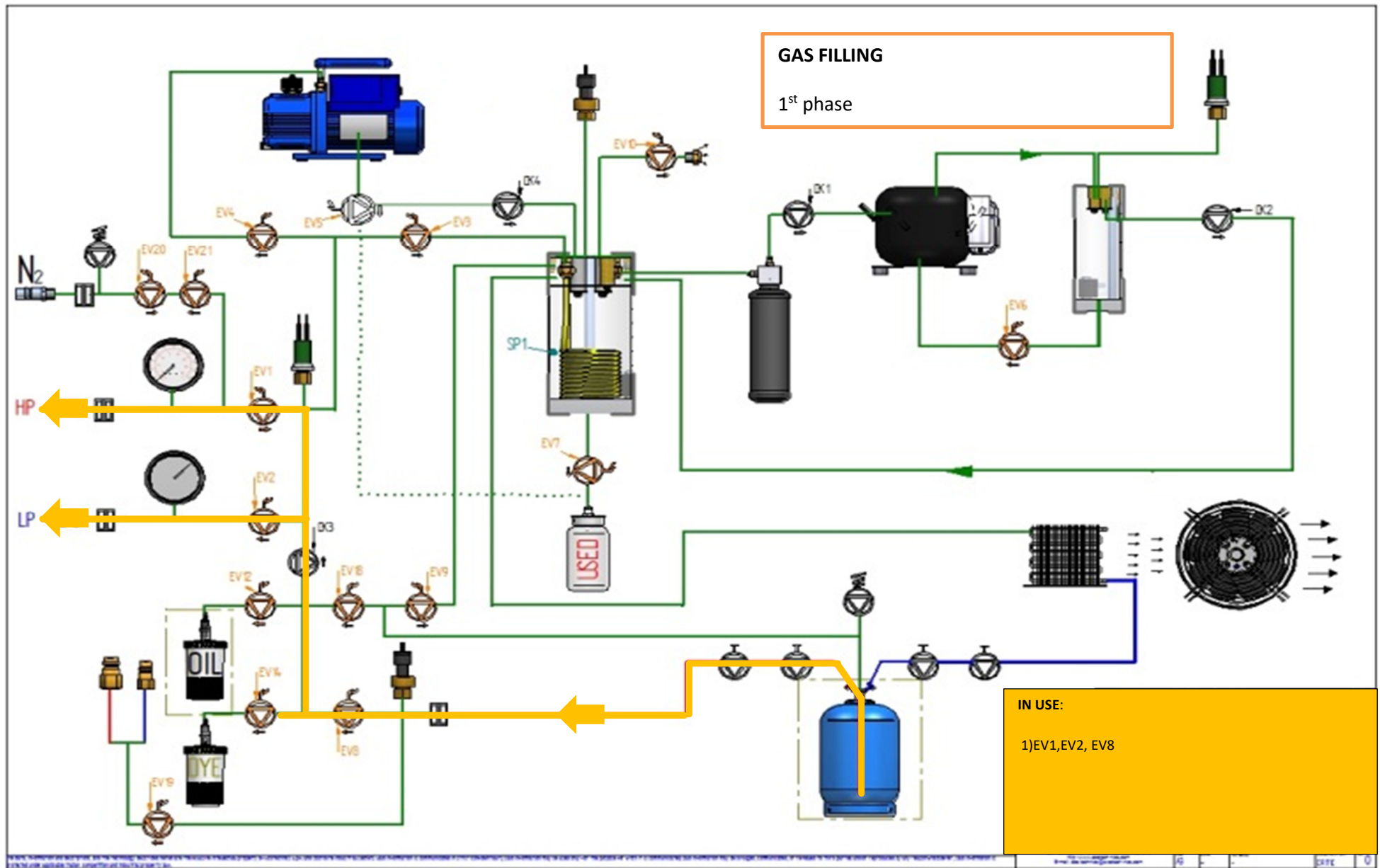

E19-TOP – Hydraulic Diagram – Phase to Phase

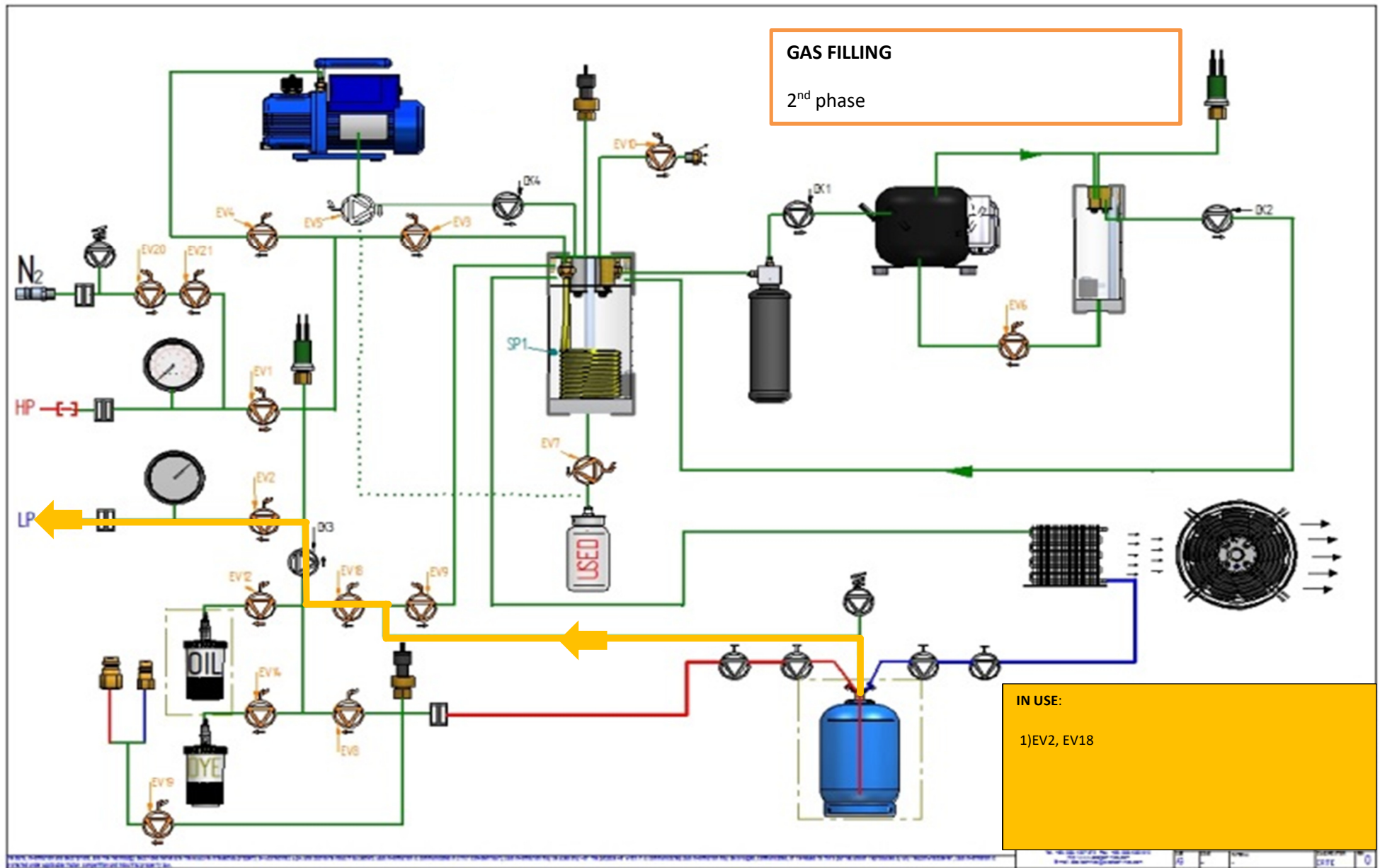

E19-TOP – Hydraulic Diagram – Phase to Phase

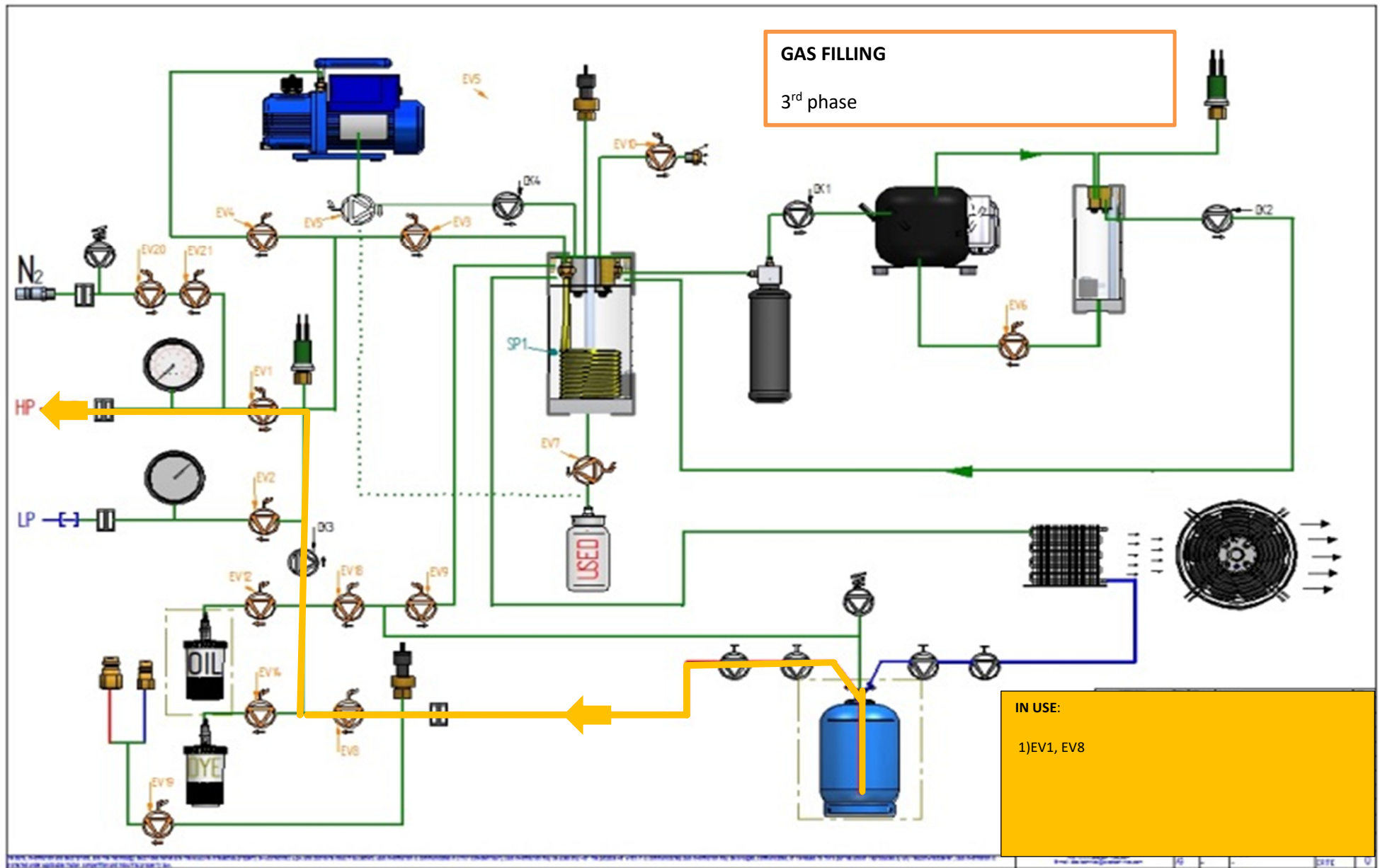

E19-TOP – Hydraulic Diagram – Phase to Phase

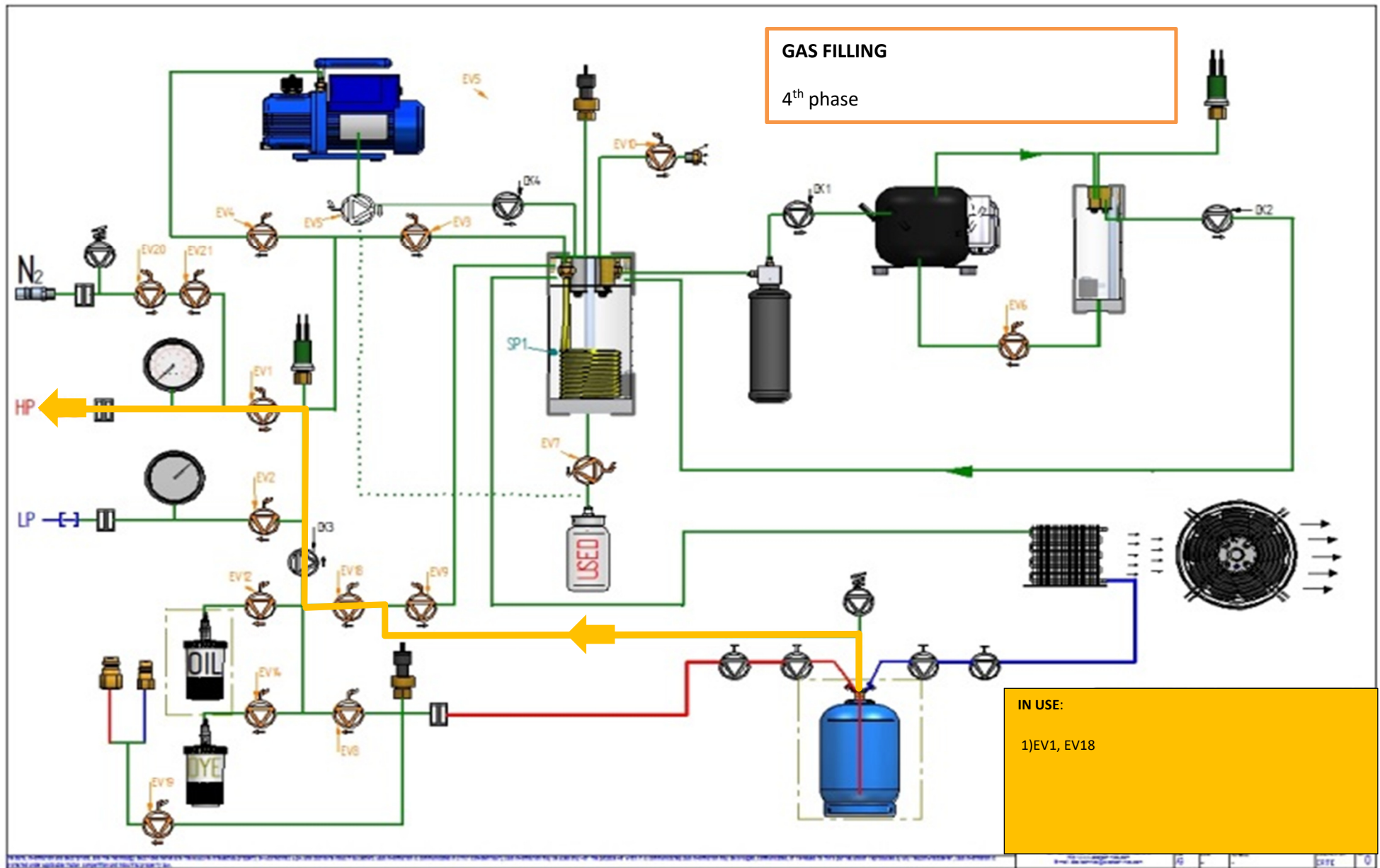

E19-TOP – Hydraulic Diagram – Phase to Phase

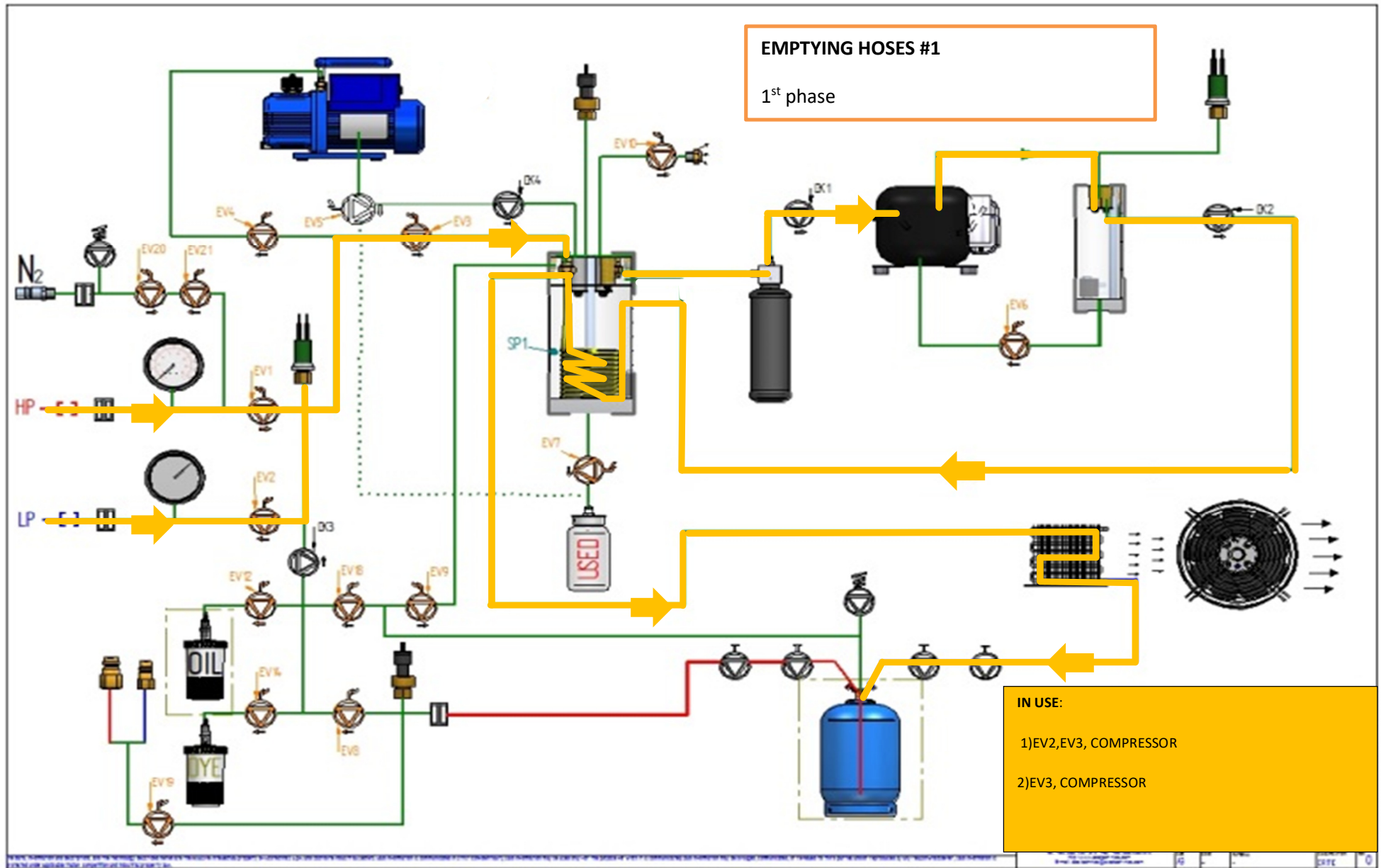

E19-TOP – Hydraulic Diagram – Phase to Phase

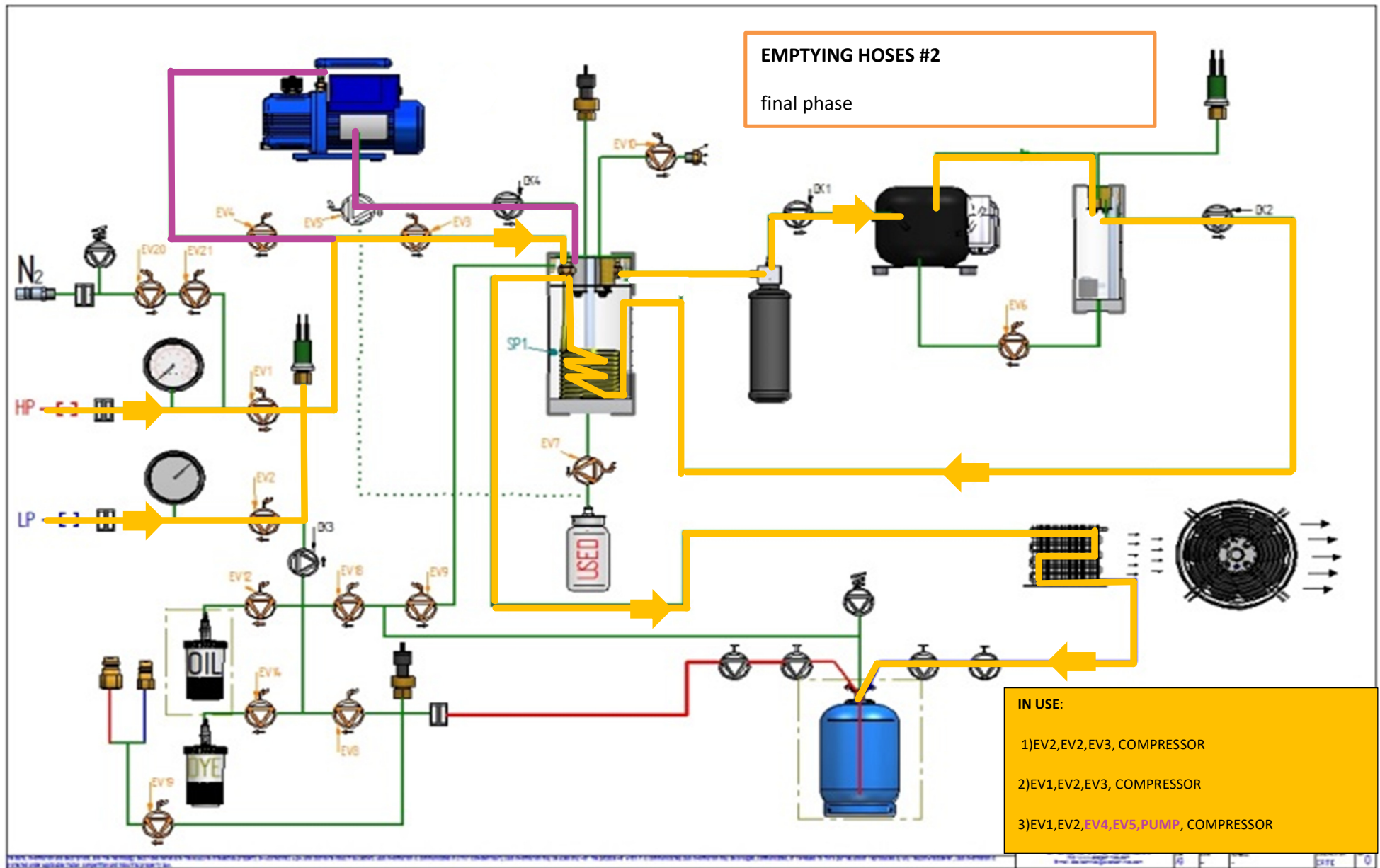

E19-TOP – Hydraulic Diagram – Phase to Phase

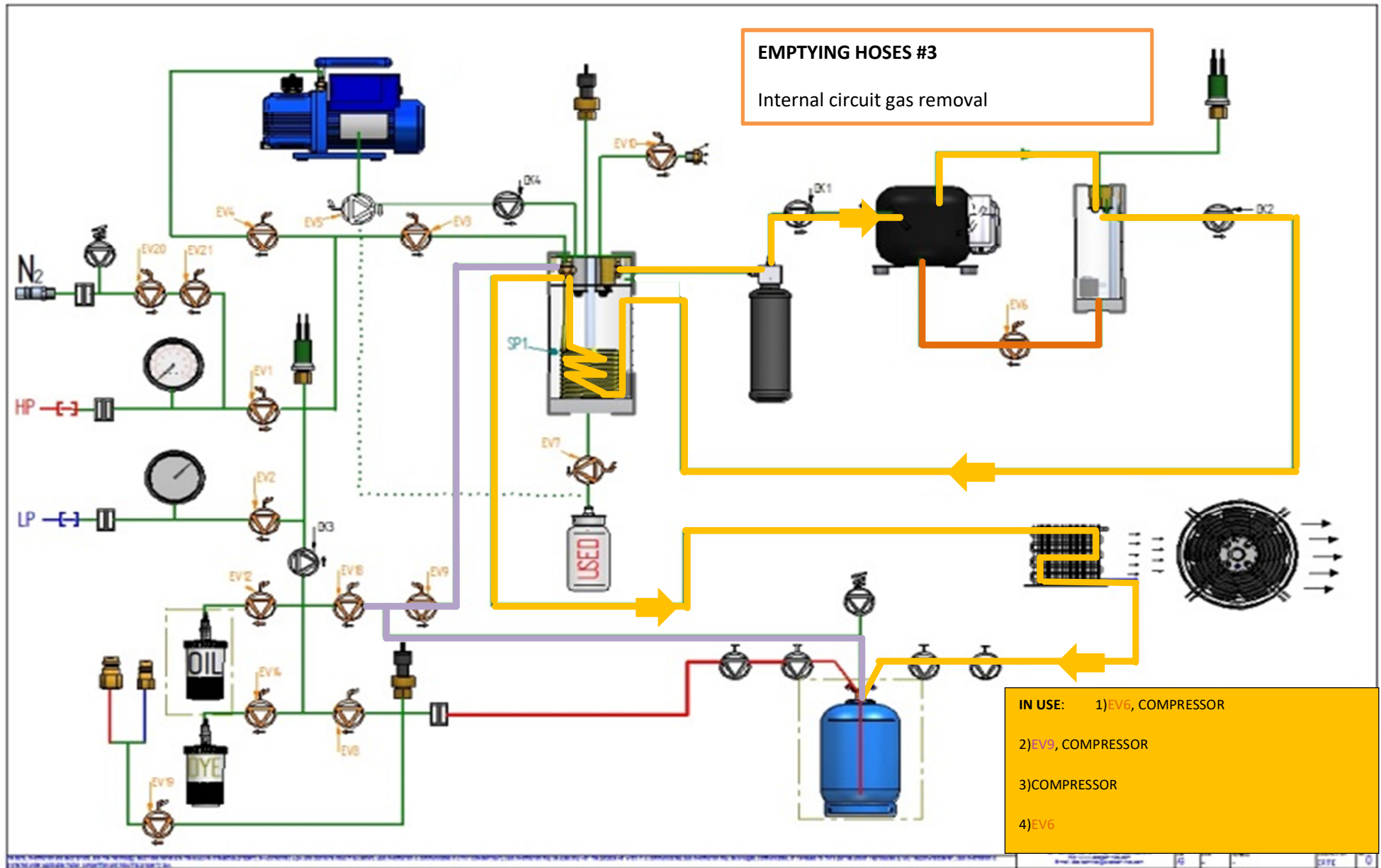

E19-TOP – Hydraulic Diagram – Phase to Phase

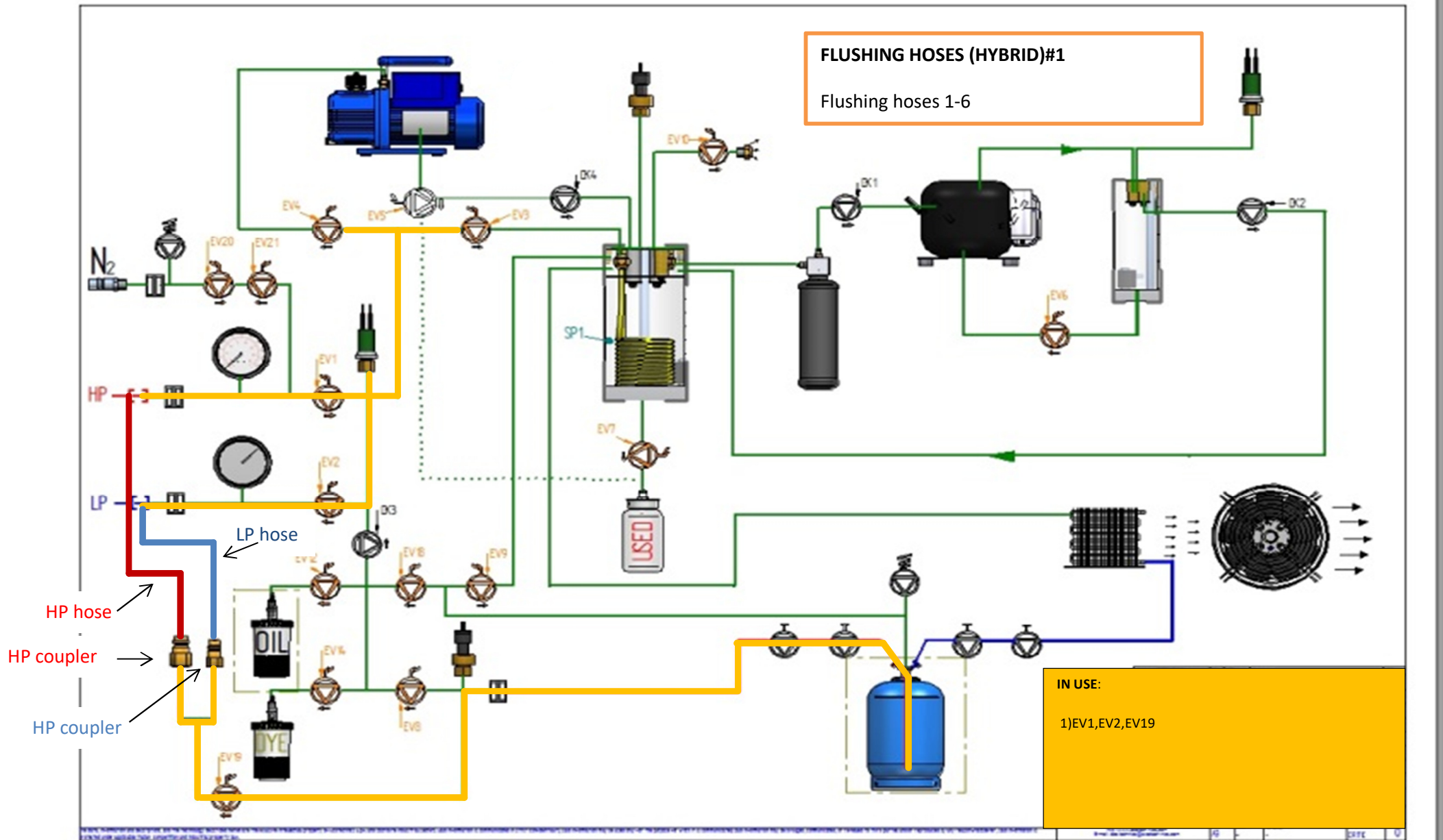

E19-TOP – Hydraulic Diagram – Phase to Phase

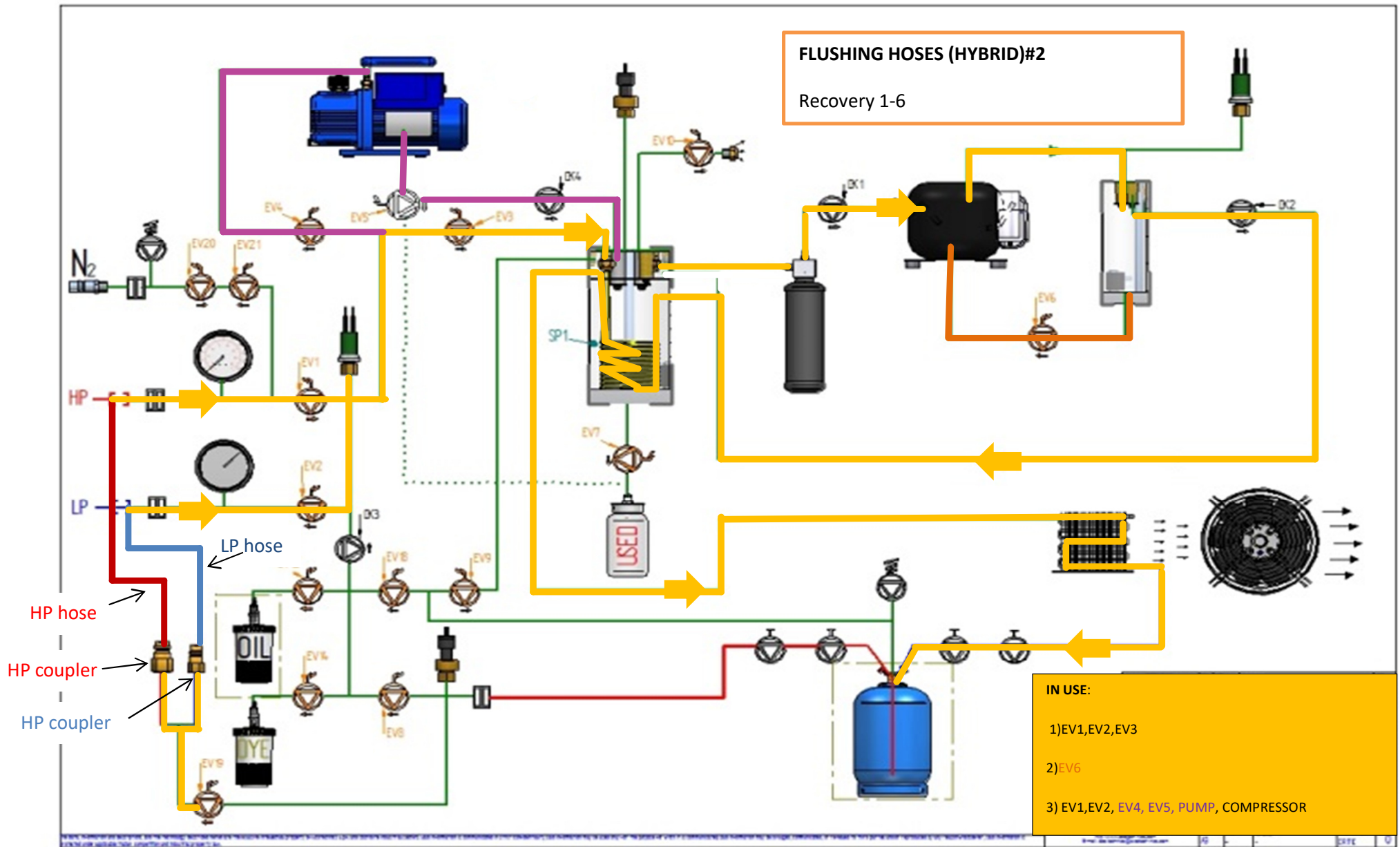

E19-TOP – Hydraulic Diagram – Phase to Phase

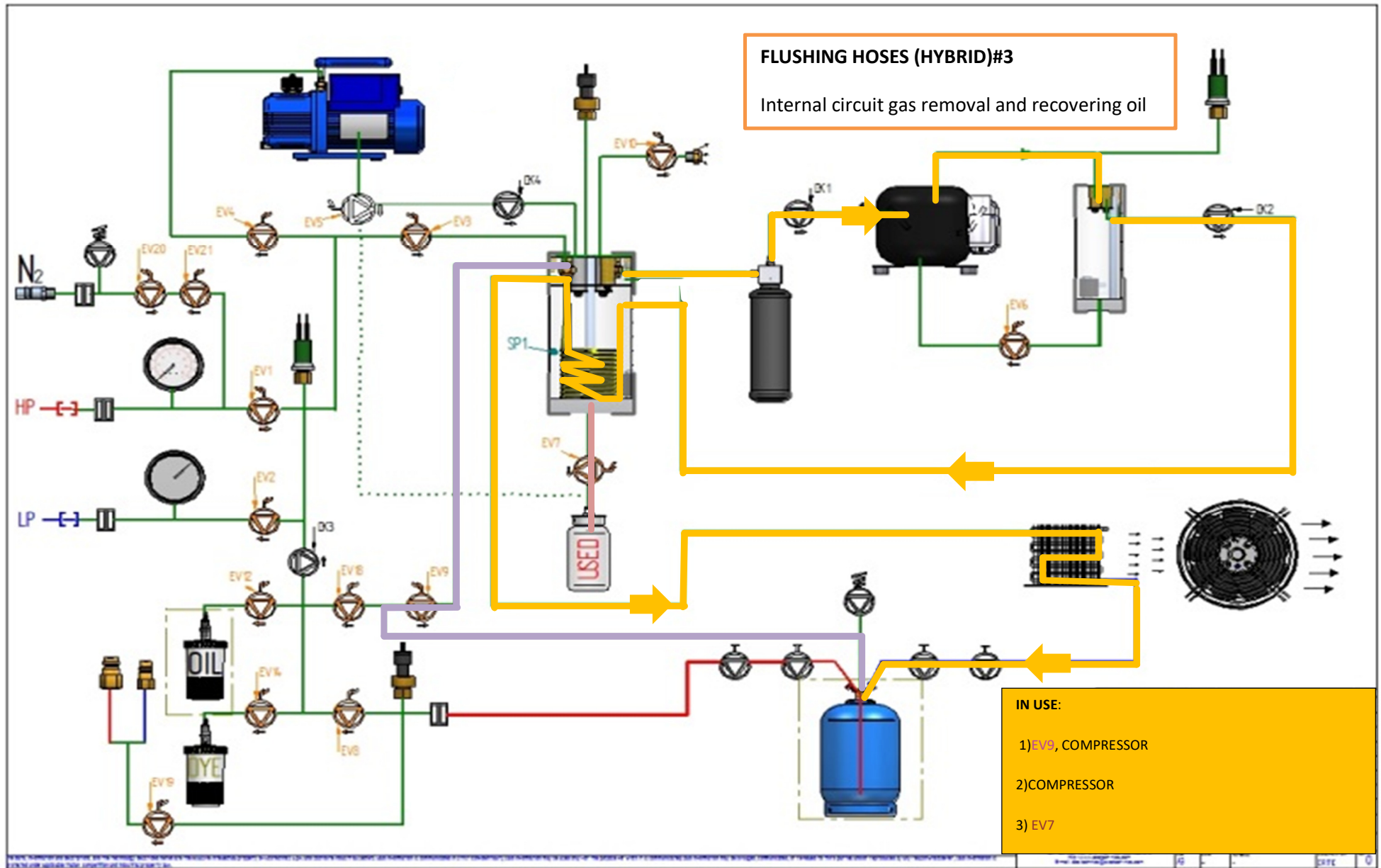

E19-TOP – Hydraulic Diagram – Phase to Phase

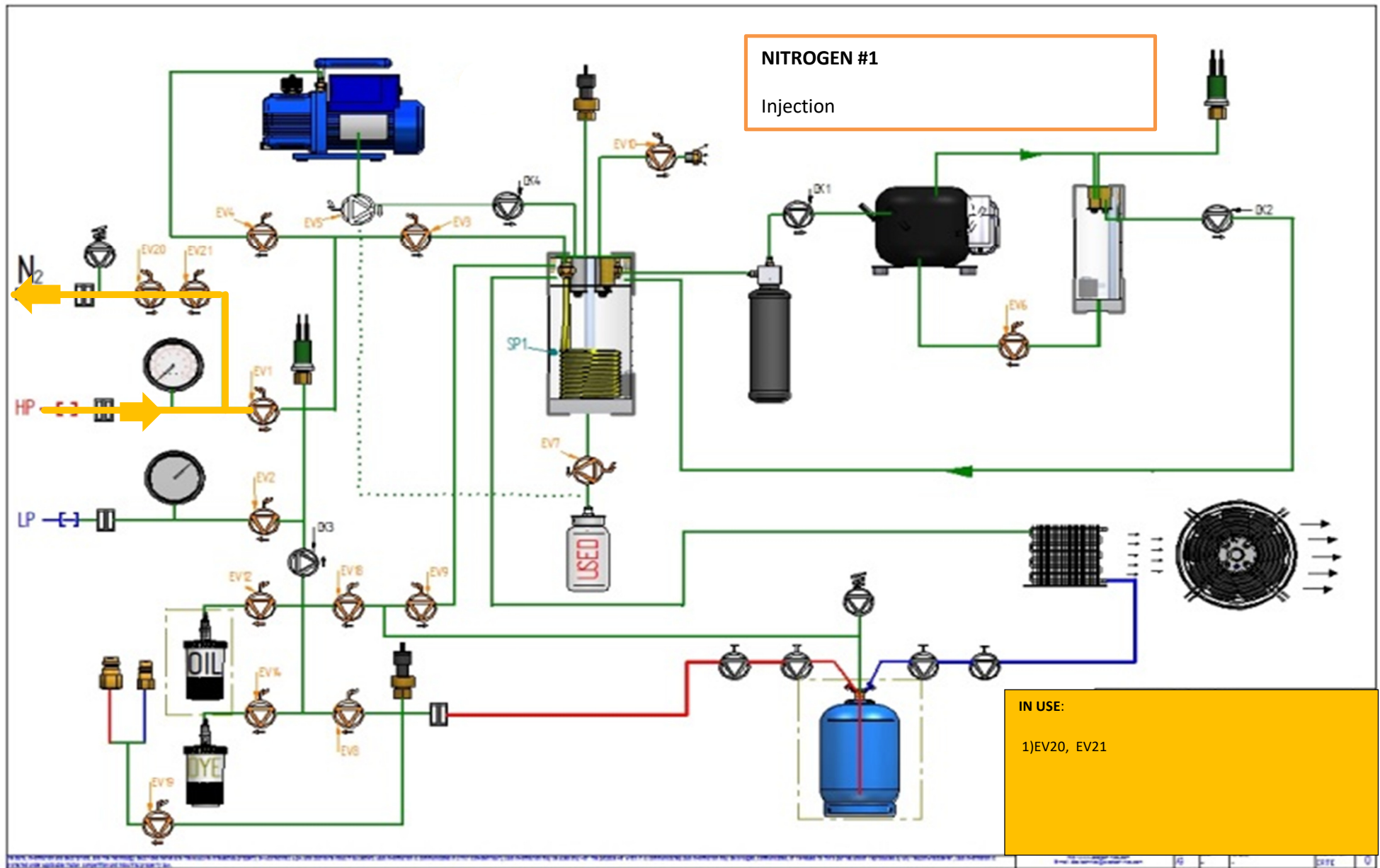

E19-TOP – Hydraulic Diagram – Phase to Phase

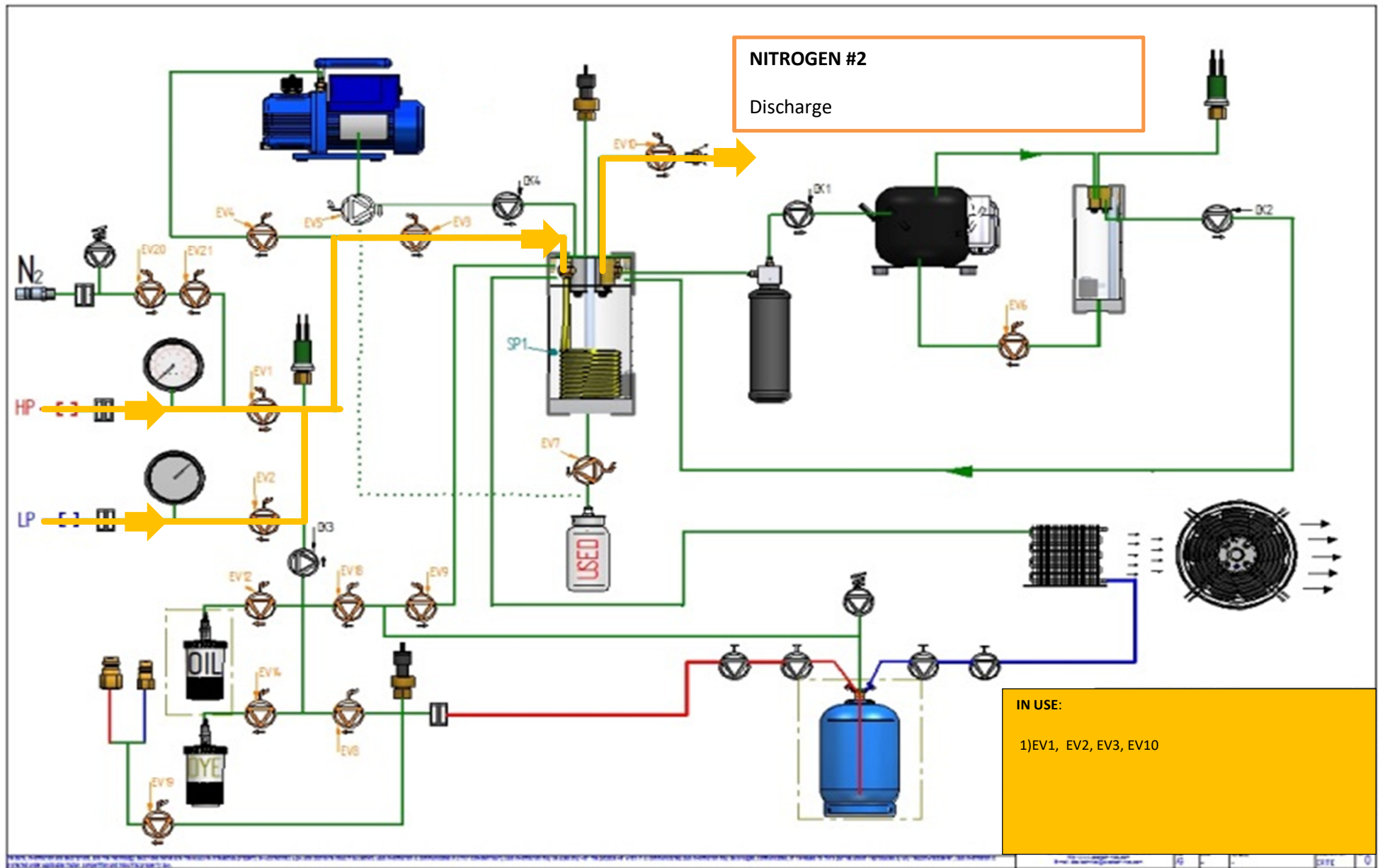

E19-TOP – Hydraulic Diagram – Phase to Phase

